



intAct **Start-Power**

Maintenance-free calcium battery (Ca/Ca) | wet charged



intAct **Start-Power**

Top performance at a great price

Developed for performance and extreme high-current capability at an absolutely perfect price-performance ratio. For almost all standard cars without many additional installations and other electrical consumers.

Our recommendation for standard applications with low requirements and the best price-performance ratio.

CHARACTERISTICS

- » **Powerful and reliable.**
- » **Double lid for increased leak protection and vapour condensation**
(gaseous electrolyte condenses in the labyrinth lid and remains in the circuit).
- » **Filled and charged.** Ready for immediate use.
- » **Maintenance-free.** No refilling of water necessary.

All information about this series can be found on the Internet:

VISIT US!



www.intact-batterien.de

Maintenance-free calcium battery (Ca/Ca) | wet charged

Item Nr.	Japan-Code	Volt	Capacity	Cold cranking amper	Length mm	Width mm	Height mm	Position of Terminal	Terminal	Base plate	Degasing	Weight/kg
52430SMF	U1	12	24 Ah (c20)	300 A (EN)	196	130	184	1	4	–	–	8,2
52440SMF	U1R	12	24 Ah (c20)	300 A (EN)	196	130	184	0	4	–	–	8,2
53030SMF	53030, 52515	12	30 Ah (c20)	300 A (EN)	187	130	170	0	G	–	–	8
53034SMF	Y60-N30-A	12	30 Ah (c20)	300 A (EN)	187	130	170	1	G	–	–	8
53211GUG	–	12	32 Ah (c20)	220 A (EN)	233	132	168	0	4	–	–	8,6
53506GUG	–	12	35 Ah (c20)	540 A (EN)	207	175	140	0	1	B13	–	10,9
53646GUG	–	12	36 Ah (c20)	300 A (EN)	207	175	175	0	1	B13	–	10,4
53880GUG	–	12	38 Ah (c20)	240 A (EN)	242	130	200	1	1	B06	–	11,2
54012RFUGUG	–	12	40 Ah (c20)	300 A (EN)	207	175	175	0	1	B13	–	11
54324GUG	NG	12	43 Ah (c20)	440 A (EN)	207	175	175	0	1	B13	–	11,4
54408GUG	–	12	44 Ah (c20)	390 A (EN)	175	175	190	0	1	B13	–	10,3
54459GUG	NG	12	44 Ah (c20)	400 A (EN)	207	175	190	0	1	B13	–	11,4
54464GUG	–	12	44 Ah (c20)	360 A (EN)	207	175	190	1	1	B13	–	12,2
55010GUG	NG	12	50 Ah (c20)	470 A (EN)	207	175	190	0	1	B13	–	12,4
55559GUG	–	12	55 Ah (c20)	420 A (EN)	242	175	190	0	1	B13	–	13,7
56077GUG	NG	12	60 Ah (c20)	540 A (EN)	242	175	175	0	1	B13	–	13,1
56219GUG	NG	12	62 Ah (c20)	540 A (EN)	242	175	190	0	1	B13	–	13,9
56221GUG	–	12	62 Ah (c20)	510 A (EN)	242	175	190	1	1	B13	–	14,4
56638GUG	–	12	66 Ah (c20)	510 A (EN)	278	175	190	0	1	B13	–	16,5
57113GUG	NG	12	71 Ah (c20)	680 A (EN)	278	175	175	0	1	B13	–	16,4
57219GUG	–	12	72 Ah (c20)	640 A (EN)	278	175	190	1	1	B13	–	16,7
57412GUG	NG	12	74 Ah (c20)	680 A (EN)	278	175	190	0	1	B13	–	16,9
58035GUG	NG	12	80 Ah (c20)	740 A (EN)	315	175	175	0	1	B13	–	18,2
58042GUG	NG	12	80 Ah (c20)	670 A (EN)	315	175	190	0	1	B13	–	18,8
58213GUG	–	12	82 Ah (c20)	720 A (EN)	315	175	190	1	1	B13	–	20,4
58821GUG	–	12	88 Ah (c20)	680 A (EN)	353	175	190	1	1	B13	–	20
58827GUG	–	12	90 Ah (c20)	720 A (EN)	353	175	190	0	1	B13	–	20,4
60010GUG	–	12	100 Ah (c20)	850 A (EN)	315	175	190	0	1	B13	–	21,4
60038GUG	NG	12	100 Ah (c20)	760 A (EN)	353	175	190	0	1	B13	–	20,9
60044GUG	NG	12	100 Ah (c20)	830 A (EN)	353	175	190	0	1	B13	–	21,8
61042GUG	NG	12	110 Ah (c20)	920 A (EN)	394	175	190	0	1	B13	–	24,8

intAct Start-Power

Maintenance-free calcium battery (Ca/Ca) | wet charged

Item Nr.	Japan-Code	Volt	Capacity	Cold cranking amper	Length mm	Width mm	Height mm	Position of Terminal	Terminal	Base plate	Degassing	Weight/kg
Intact Start-Power Asia												
53504GUG	NG	12	35 Ah (c20)	300 A (EN)	187	127	227	0	3	B01	-	8,4
53520GUG	NG	12	35 Ah (c20)	300 A (EN)	187	127	227	0	3	-	-	9,8
53522GUG	NG	12	35 Ah (c20)	300 A (EN)	187	127	227	1	3	-	-	9,8
54523GUG	NG	12	45 Ah (c20)	330 A (EN)	237	127	225	0	1	-	-	11,7
54524GUG	NG	12	45 Ah (c20)	330 A (EN)	237	127	225	1	1	-	-	11,7
54577GUG	NG	12	45 Ah (c20)	300 A (EN)	220	135	225	0	1	B01	-	11,5
54579GUG	NG	12	45 Ah (c20)	300 A (EN)	220	135	225	1	1	B01	-	11,6
55041BGUG	-	12	50 Ah (c20)	360 A (EN)	200	170	225	0	1	B01	-	13
55042GUG	-	12	50 Ah (c20)	360 A (EN)	200	170	225	1	1	-	-	13
56068GUG	NG	12	60 Ah (c20)	510 A (EN)	230	172	220	0	1	-	-	14,5
56068BGUG	NG	12	60 Ah (c20)	480 A (EN)	230	172	220	0	1	B01	-	15,5
56069GUG	NG	12	60 Ah (c20)	510 A (EN)	230	172	220	1	1	-	-	14,5
56069BGUG	NG	12	60 Ah (c20)	480 A (EN)	230	172	220	1	1	B01	-	15,2
57024GUG	NG	12	70 Ah (c20)	550 A (EN)	260	175	225	1	1	B01	-	16,1
57029GUG	NG	12	70 Ah (c20)	550 A (EN)	260	175	225	0	1	B01	-	16,1
60032GUG	NG	12	100 Ah (c20)	830 A (EN)	304	173	220	0	1	B01	-	20,7
60033GUG	NG	12	100 Ah (c20)	830 A (EN)	304	173	220	1	1	B01	-	20,7

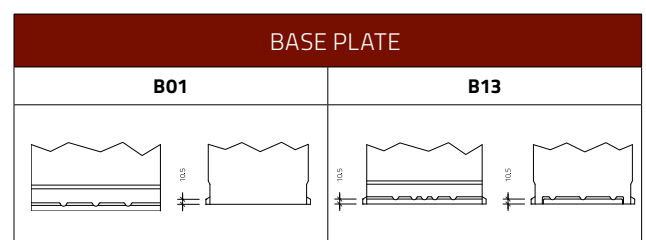
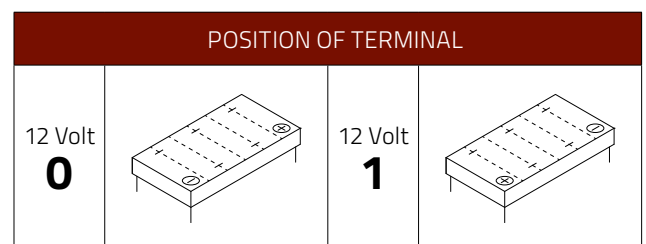
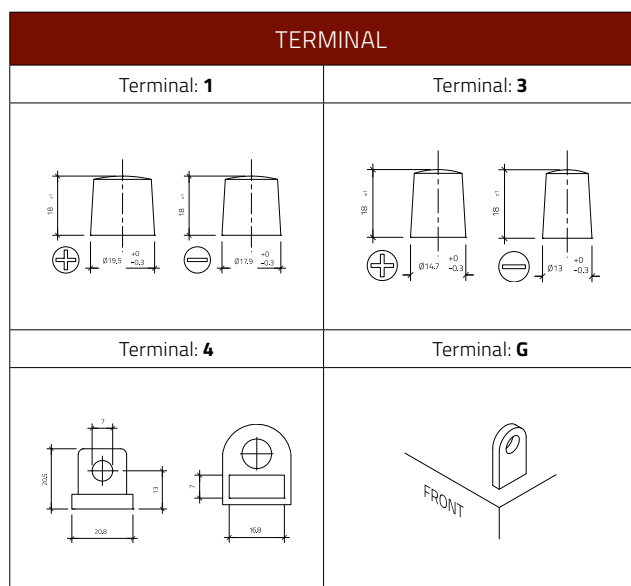

Stand: September 2025