



**For motorhomes, caravans and boats with moderate energy demands.**

The Professional EFB battery is the ideal companion for short off-grid adventures. Designed for moderate energy demands, it ensures enjoyable weekend getaways without worry. Engineered in Germany, VARTA batteries deliver precision performance and lasting reliability.

**VEHICLE KEY BENEFITS**



**Up to 3x cycle life**

Up to 3x cycle life compared with a conventional battery.



**Dual purpose power**

Ideal for dual power applications (starting and overall energy supply).



**Engineered in Germany**

Engineered with precision and expertise in Germany.



**Maintenance-free**

Maintenance-free battery designed to deliver dependable performance for your vehicle.

**TECHNICAL DATA**

Capacity:	<b>60 Ah</b>	CCA:	<b>640 A</b>
Voltage:	<b>12 V</b>	Dimensions (L/W/H):	<b>242/175/190</b>
Case Size:	<b>H5/L2 EFB</b>	Short Code:	<b>LED60</b>
UK-Code:	<b>027EFB</b>	ETN:	<b>932060064</b>
Weight filled:	<b>16,49 kg</b>	Base Hold-down:	<b>B13</b>
Layout:	<b>0</b>	Terminal Type:	<b>1</b>

**DRAWINGS**

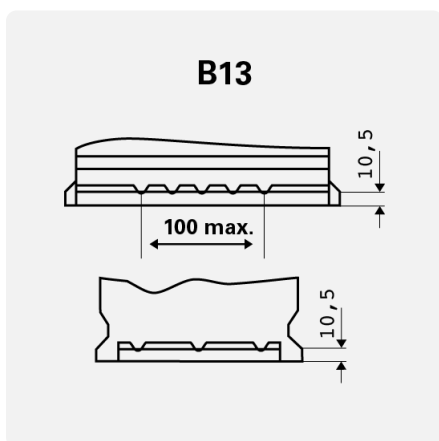

**Base Hold-down**

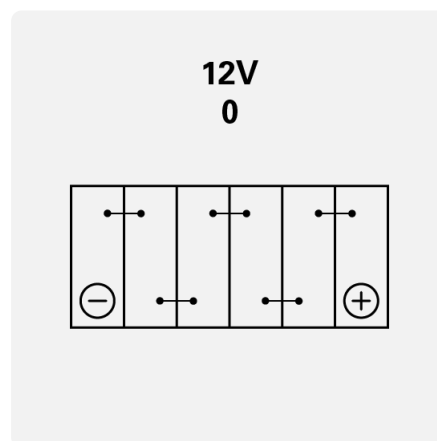

**Layout**

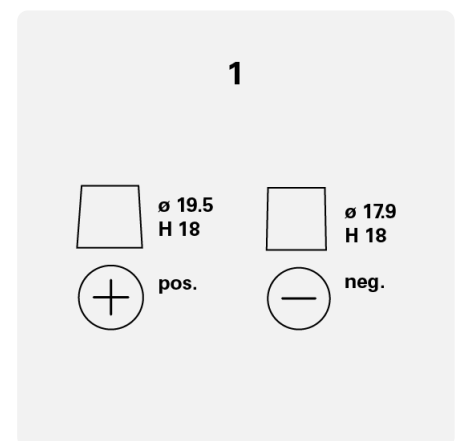

**Terminal Type**